

# PARTS MANUAL



## **MODEL WT5C/WTE5C WATER TRAILERS (HONDA GX120UT2PX2 GASOLINE ENGINE) (QP2HLF CENTRIFUGAL PUMP)**

Revision #1 (07/11/13)

To find the latest revision of this  
publication, visit our website at:  
[www.multiquip.com](http://www.multiquip.com)



**THIS MANUAL MUST ACCOMPANY THE EQUIPMENT AT ALL TIMES.**

**PN 49859**

# TABLE OF CONTENTS

---

## **WT5C/WTE5C Water Trailer**

Table Of Contents.....	2
Parts Ordering Procedures.....	3
Explanation Of Code In Remarks Column.....	4
Suggested Spare Parts .....	5

## **Component Drawings**

Nameplate and Decals Assembly.....	6-7
Water Tank Assembly .....	8-9
Engine Mounting And Hose Assembly.....	10-11
Manifold Assembly.....	12-13
Manifold Valve Assembly .....	14-15
Rear Spray Valve Assembly .....	16-17
Tank Cradle Mounting Assembly .....	18-19
Tank Cradle Assembly .....	20-21
Hydraulic Trailer Assembly .....	22-25
Electric Trailer Assembly.....	26-27
Terms And Conditions Of Sale — Parts .....	28

### **NOTICE**

Specifications and part numbers are subject to change without notice.

# PARTS ORDERING PROCEDURES

## Ordering parts has never been easier! Choose from three easy options:

Effective:  
January 1<sup>st</sup>, 2006

www.multiquip.com



### Order via Internet (Dealers Only):

Order parts on-line using Multiquip's SmartEquip website!

- View Parts Diagrams
- Order Parts
- Print Specification Information



If you have an MQ Account, to obtain a Username and Password, E-mail us at: [parts@multiquip.com](mailto:parts@multiquip.com).

To obtain an MQ Account, contact your District Sales Manager for more information.

Goto [www.multiquip.com](http://www.multiquip.com) and click on

**Order Parts** to log in and save!

Use the **internet** and qualify for a **5% Discount** on *Standard orders* for all orders which include complete part numbers.\*

Note: Discounts Are Subject To Change

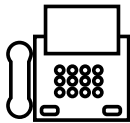

### Order via Fax (Dealers Only):

All customers are welcome to order parts via Fax.

**Domestic (US) Customers dial:**  
1-800-6-PARTS-7 (800-672-7877)

**Fax** your order in and qualify for a **2% Discount** on *Standard orders* for all orders which include complete part numbers.\*

Note: Discounts Are Subject To Change



**Order via Phone: Domestic (US) Dealers Call:**  
1-800-427-1244

### Non-Dealer Customers:

Contact your local Multiquip Dealer for parts or call 800-427-1244 for help in locating a dealer near you.



**International Customers** should contact their local Multiquip Representatives for Parts Ordering information.

## When ordering parts, please supply:

- |   |  |
|---|--|
| <input type="checkbox"/> Dealer Account Number                                | <input type="checkbox"/> Specify Preferred Method of Shipment:                         |
| <input type="checkbox"/> Dealer Name and Address                              | <input checked="" type="checkbox"/> UPS/Fed Ex <input checked="" type="checkbox"/> DHL |
| <input type="checkbox"/> Shipping Address (if different than billing address) | <input type="checkbox"/> Priority One <input checked="" type="checkbox"/> Truck        |
| <input type="checkbox"/> Return Fax Number                                    | <input type="checkbox"/> Ground  |
| <input type="checkbox"/> Applicable Model Number                              | <input type="checkbox"/> Next Day  |
| <input type="checkbox"/> Quantity, Part Number and Description of Each Part   | <input type="checkbox"/> Second/Third Day  |

### NOTICE

All orders are treated as *Standard Orders* and will ship the same day if received prior to 3PM PST.

WE ACCEPT ALL MAJOR CREDIT CARDS!



# EXPLANATION OF CODE IN REMARKS COLUMN

The following section explains the different symbols and remarks used in the Parts section of this manual. Use the help numbers found on the back page of the manual if there are any questions.

**NOTICE**

The contents and part numbers listed in the parts section are subject to change **without notice**. Multiquip does not guarantee the availability of the parts listed.

## SAMPLE PARTS LIST

NO.	PART NO.	PART NAME	QTY.	REMARKS
1	12345	BOLT .....	1	INCLUDES ITEMS W/%
2%		WASHER, 1/4 IN. ....		NOT SOLD SEPARATELY
2%	12347	WASHER, 3/8 IN. ...	1	MQ-45T ONLY
3	12348	HOSE .....	A/R	MAKE LOCALLY
4	12349	BEARING .....	1	S/N 2345B AND ABOVE

## NO. Column

**Unique Symbols** — All items with same unique symbol

(@, #, +, %, or >) in the number column belong to the same assembly or kit, which is indicated by a note in the “Remarks” column.

**Duplicate Item Numbers** — Duplicate numbers indicate multiple part numbers, which are in effect for the same general item, such as different size saw blade guards in use or a part that has been updated on newer versions of the same machine.

**NOTICE**

When ordering a part that has more than one item number listed, check the remarks column for help in determining the proper part to order.

## PART NO. Column

**Numbers Used** — Part numbers can be indicated by a number, a blank entry, or TBD.

TBD (To Be Determined) is generally used to show a part that has not been assigned a formal part number at the time of publication.

A blank entry generally indicates that the item is not sold separately or is not sold by Multiquip. Other entries will be clarified in the “Remarks” Column.

## QTY. Column

**Numbers Used** — Item quantity can be indicated by a number, a blank entry, or A/R.

A/R (As Required) is generally used for hoses or other parts that are sold in bulk and cut to length.

A blank entry generally indicates that the item is not sold separately. Other entries will be clarified in the “Remarks” Column.

## REMARKS Column

Some of the most common notes found in the “Remarks” Column are listed below. Other additional notes needed to describe the item can also be shown.

**Assembly/Kit** — All items on the parts list with the same unique symbol will be included when this item is purchased.

Indicated by:

“INCLUDES ITEMS W/(unique symbol)”

**Serial Number Break** — Used to list an effective serial number range where a particular part is used.

Indicated by:

“S/N XXXXX AND BELOW”

“S/N XXXX AND ABOVE”

“S/N XXXX TO S/N XXX”

**Specific Model Number Use** — Indicates that the part is used only with the specific model number or model number variant listed. It can also be used to show a part is NOT used on a specific model or model number variant.

Indicated by:

“XXXXX ONLY”

“NOT USED ON XXXX”

**“Make/Obtain Locally”** — Indicates that the part can be purchased at any hardware shop or made out of available items. Examples include battery cables, shims, and certain washers and nuts.

**“Not Sold Separately”** — Indicates that an item cannot be purchased as a separate item and is either part of an assembly/kit that can be purchased, or is not available for sale through Multiquip.

## SUGGESTED SPARE PARTS

---

### WT5C/WTE5C WATER TRAILER WITHQP2HLF PUMP AND GX120U1PX2 HONDA ENGINE

1 to 3 units

Qty.	P/N	Description
1.....	KIT204.....	KIT, PUMP, MECHANICAL SEAL, O-RINGS & ADJ. LINERS
1.....	0631211100	ASSY DRAIN CAP, FLOODING, W/ O-RING
2.....	17210ZE0505.....	ELEMENT, AIR CLEANER, DUAL
3.....	9807955855.....	SPARK PLUG
1.....	28462ZH8003.....	ROPE, RECOIL STARTER
1.....	17620Z0T305.....	CAP, FUEL W/ GASKET

#### **NOTICE**

Part numbers on this Suggested Spare Parts list may supersede/replace the part numbers shown in the following parts lists.



## NAMEPLATE AND DECALS

---

<u>NO.</u>	<u>PART NO.</u>	<u>PART NAME</u>	<u>QTY.</u>	<u>REMARKS</u>
1	35137	DECAL, READ MANUAL ASK FR TRAINING 2.75"	1	
2	36099	DECAL, PROTECTIVE CLOTHING	1	
3	49937	DECAL, VALVE OPERATION, WTC	1	
4	29440	DECAL, PLUG WIRING .....	1.....	WTE5C ONLY
5	EE56342	DECAL, NATM COMPLIANCE	1	
6	49002	DECAL, TRLR HITCH/WHEEL WARNING	1	
7	EE56313	OVERLAY, VIN LABEL	1	
8	EE56314	OVERLAY, TIRE LABEL	1	
9		LABEL, VIN AND TIRE .....	1.....	CONTACT MQ PARTS DEPT.
10	29713	DECAL, BRAKE FLUID CHECK	1	

**WATER TANK ASSY.**

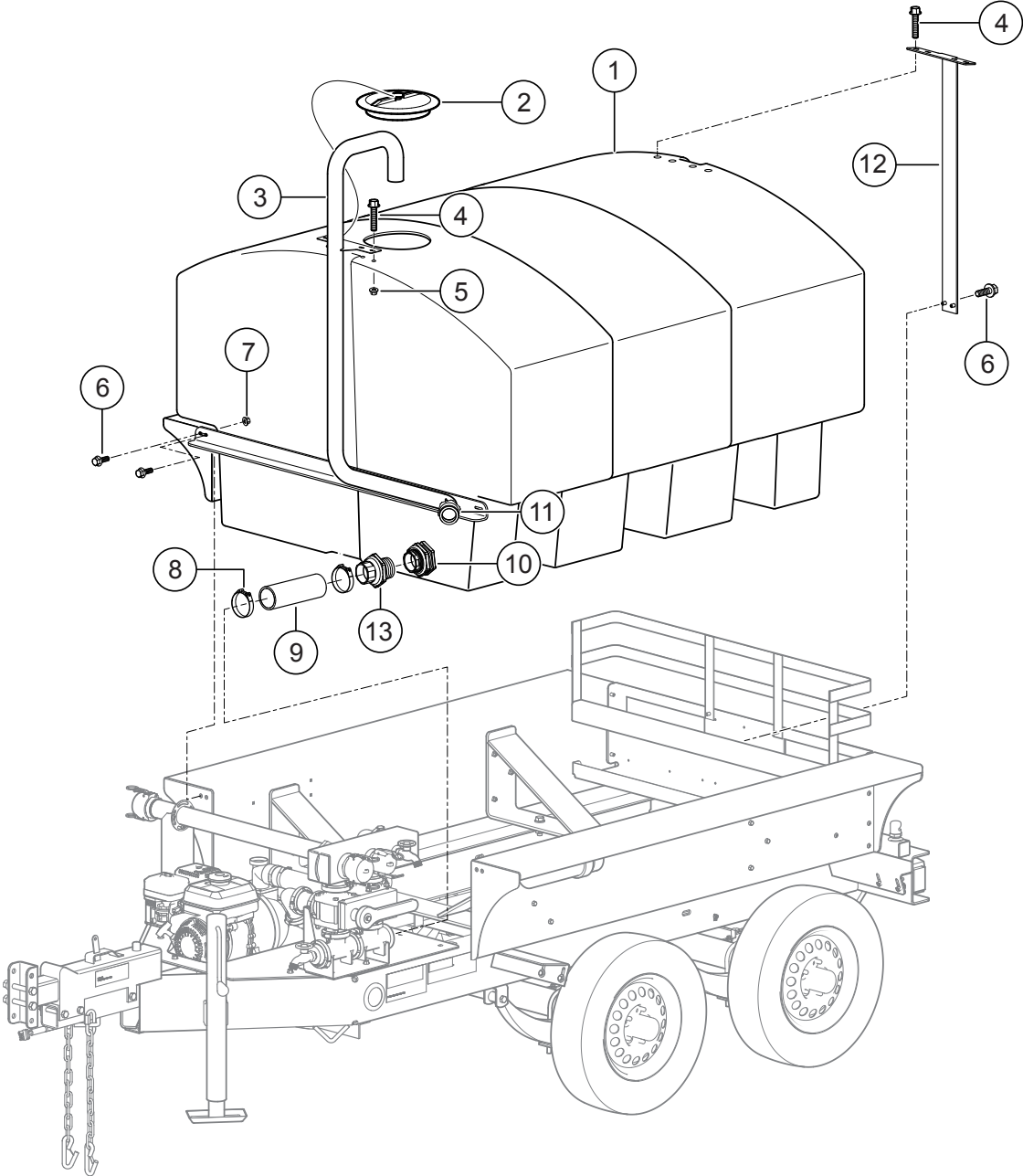



## WATER TANK ASSY.

---

<u>NO.</u>	<u>PART NO.</u>	<u>PART NAME</u>	<u>QTY.</u>	<u>REMARKS</u>
1@		TANK, 500 GAL.....	1.....	NOT SERVICED SEPARATELY
2@	49906	LID, TANK, W/TETHER	1	
3	49765	RISER, HYDRANT FILL, ASSY. ....	1.....	INCLUDES ITEM W/%
4	23619	SCREW, HHFS 1/4-20 X 1-1/4" ZP	4	
5@	34159	NUT, BLIND 1/4-20 BULB TYPE	8	
6	49048	SCREW, HHFS 1/4-20 x 3/4" GR5	6	
7	49070	NUT, FLANGED, 1/4-20 SERRATED PLTD	4	
8	49783	CLAMP, HOSE, BARREL, 2.2-2.5"	2	
9	49849	HOSE, RUBBER, 2", 125PSI 5.5" LONG .....	1.....	1PC=1FT
10@	49768	FITTING, BULKHEAD, 2", BNJ	1	
11%	49672	FITTING, 2" FNPT X 2" M CAM & GROOVE	1	
12	49893	BRACKET TANK SUPPORT	1	
13@	49903	FITTING, 2" MNPT X 2" BARB TRIMMED	1	
14	49769	TANK ASSY., 500 GAL.	1	INCLUDES ITEMS W/@

# ENGINE MOUNTING AND HOSE ASSY.

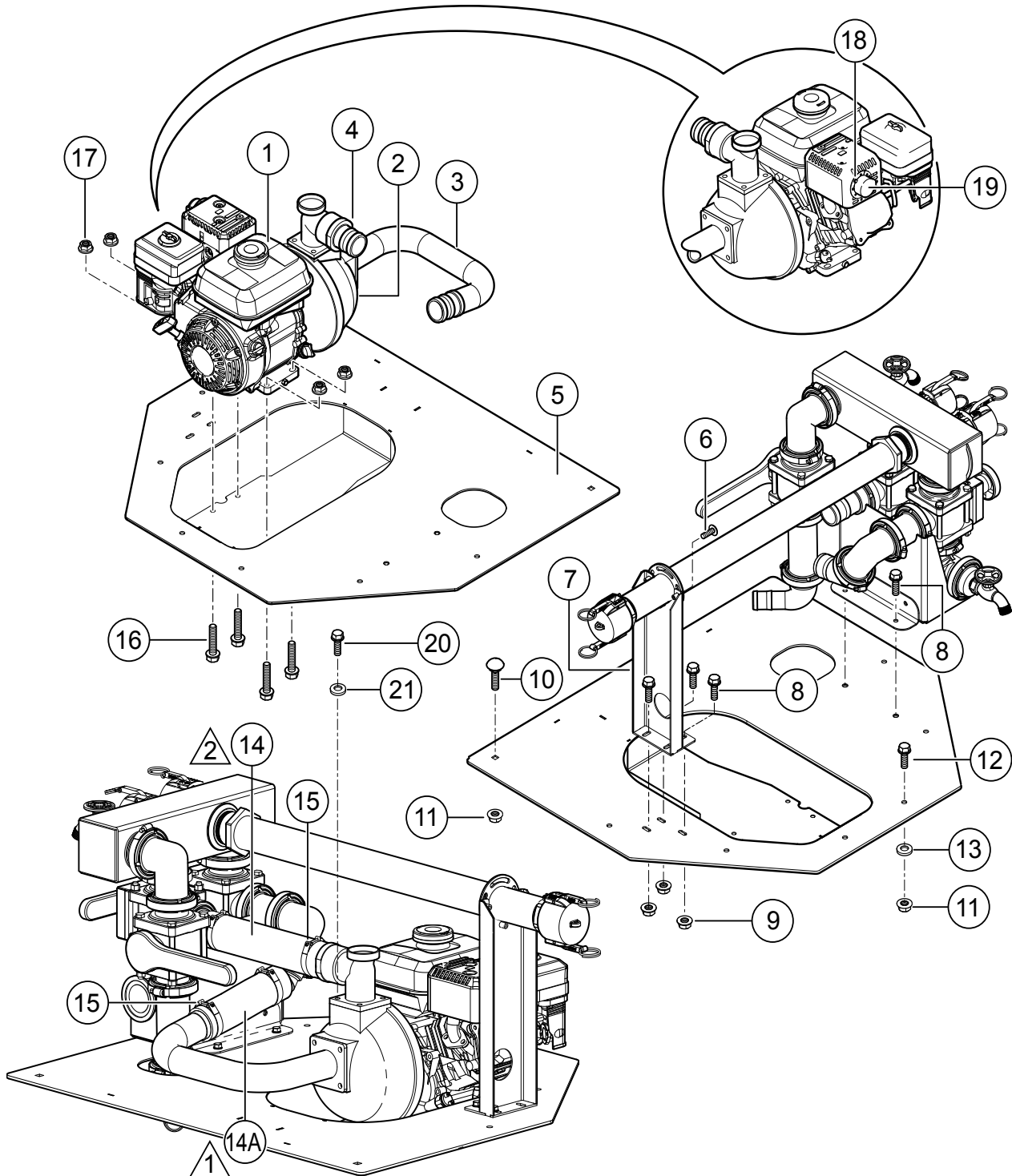

NOTE:

- ① LOWER HOSE ITEM 14A MUST BE CUT TO 8" LONG.
- ② UPPER HOSE ITEM 14 IS 12" LONG.

## ENGINE MOUNTING AND HOSE ASSY.

<u>NO.</u>	<u>PART NO.</u>	<u>PART NAME</u>	<u>QTY.</u>	<u>REMARKS</u>
1#	GX120U1PX2	ENGINE, HONDA	1	
2	QP2HLF	PUMP, CENTRIFUGAL, LESS FRAME .....	1.....	INCLUDES ITEM W/#
3	49761	PUMP INLET W/A, 2" BARB	1	
4	49762	FITTING, 2" NPSM X 2" BARB	1	
5	49939	DECK PLATE W/A	1	
6	49048	SCREW, HHFS 1/4-20 X 3/4" GRD 5	3	
7	49743	SUPPORT, SIDE SPRAY, W/A	1	
8	9091	SCREW, HHFS 5/16-18 X 1", GR5	5	
9	49071	NUT, FLANGED 5/16-18 SERRATED PLTD	3	
10	23517	BOLT, CARRIAGE 3/8-16 X 1-1/4", GR5	2	
11	10133	NUT, NYLOC 3/8-16	8	
12	22106	SCREW, HHFS 3/8-16 X 1-1/4" ZINC	6	
13	3233	WASHER, FENDER, 1.5 OD X 3/8 ID	6	
14	49849	HOSE, RUBBER, 2", 125PSI 12" LONG .....	1.....	1PC=1FT
14A	49908	HOSE, RUBBER, 2", 125PSI 8" LONG .....	1.....	1PC=1FT
15	49783	CLAMP, HOSE, BARREL, 2.3-2.6	4	
16	21906	SCREW, HHFS 5/16-18 X 1-1/2" GRD 5	4	
17	49071	NUT, FLANGED 5/16-18 SERRATED PLTD	4	
18	1273	SCREW, HHWTC 8-32 X 3/8"	2	
19	1834	DEFLECTOR, HONDA EXHAUST, 5HP	1	
20	2866	SCREW, HHC M8-1.25 X 20 MM	8	
21	0161 C	WASHER, LOCK 5/16 MED.	8	

**MANIFOLD ASSY.**

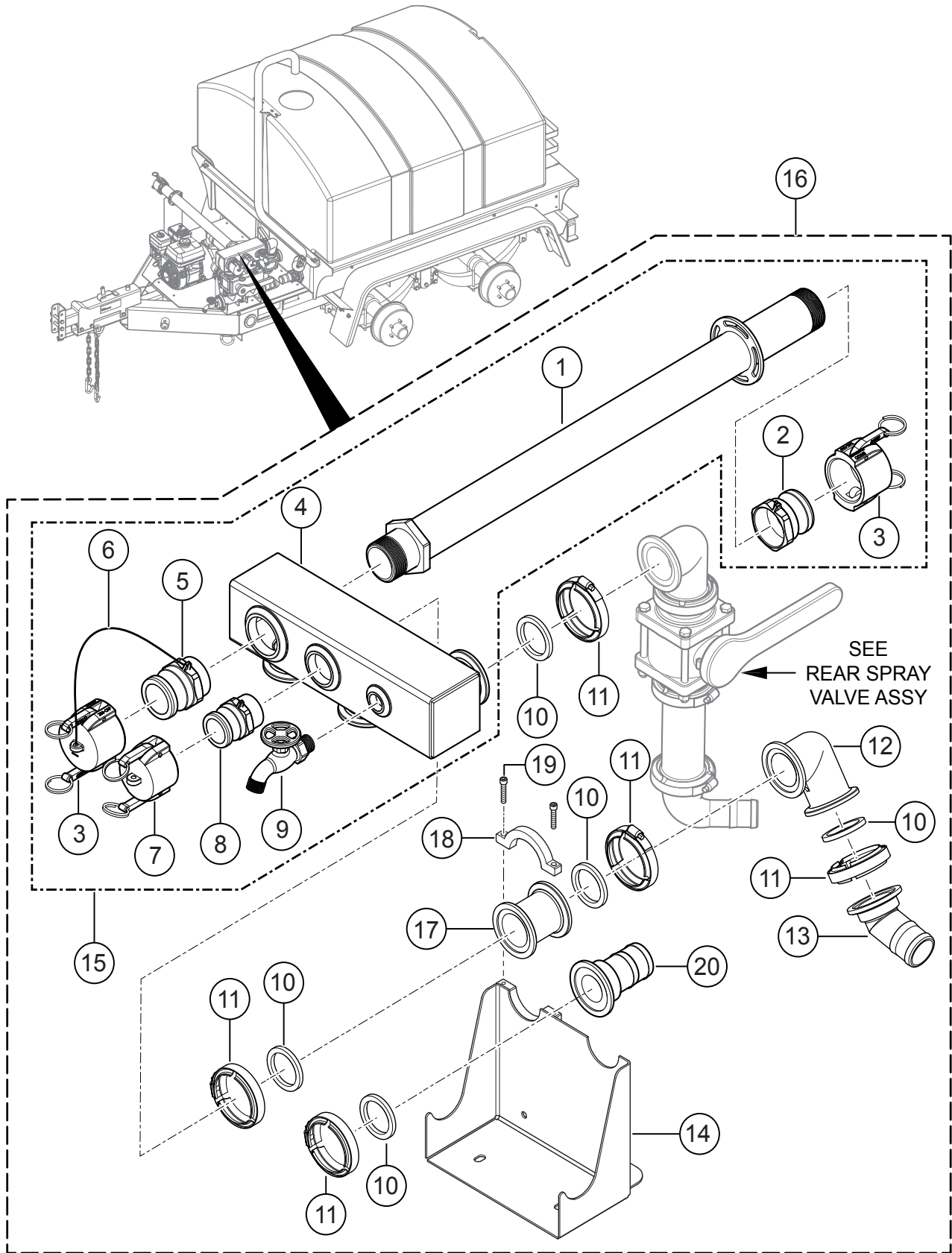

## MANIFOLD ASSY.

<u>NO.</u>	<u>PART NO.</u>	<u>PART NAME</u>	<u>QTY.</u>	<u>REMARKS</u>
1%#	49682	TUBE, SIDE SPRAY, W/A	1	
2%#	49672	FITTING, 2" FNPT X 2" M CAM LEVER	1	
3%#	49668	CAP, DUST, 2", CAM LEVER	2	
4%#	49675	MANIFOLD, UPPER,	1	
5%#	49671	FITTING, 2" MNPT X 2" M CAM LEVER	1	
6%#	49732	LANYARD, 11" POLY	3	
7%#	49668	CAP, DUST, 1-1/2", CAM LEVER	1	
8%#	49673	FITTING, 1-1/2" MNPT X 1-1/2" M CAM	1	
9%#	49683	HOSE BIB, 3/4" MNPT	1	
10#	49663	GASKET, 2" FP, EPDM, BNJ	5	
11#	49664	CLAMP, HOSE WORM, 2" FP, BNJ	5	
12#	49669	FITTING, 90°, 2" FP, BNJ	1	
13#	49774	FITTING, 45°, 2" FP X 2" BARB, BNJ	1	
14#	49904	MANIFOLD SUPPORT W/A	1	
15#	49731	MANIFOLD, UPPER, ASSY. ....	1	INCLUDES ITEMS W/%
16	49740	MANIFOLD, ASSY. ....	1	INCLUDES ITEMS W/#
17#	49735	FITTING, NIPPLE, BNJ2" FPX3" L.	1	
18#	49896	CLAMP, HALF, MANIFOLD , TOP	1	
19#	09689-010	SCREW, SHC 1/4-20 X 1-1/4"	2	
20#	49899	FITTING, 2" FP X 2" BARB, BNT	1	

# MANIFOLD VALVE ASSY.

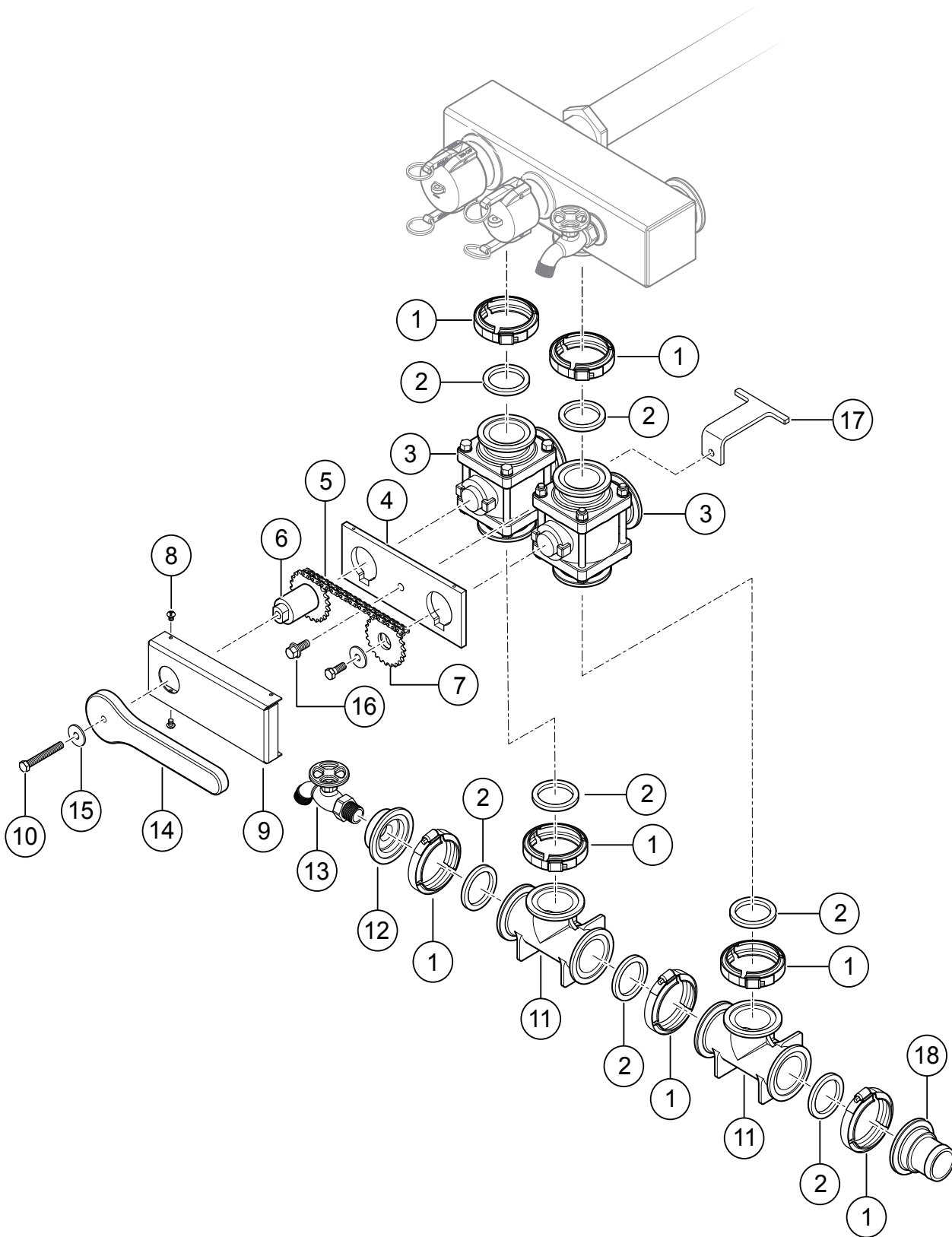

## MANIFOLD VALVE ASSY.

---

<u>NO.</u>	<u>PART NO.</u>	<u>PART NAME</u>	<u>QTY.</u>	<u>REMARKS</u>
1	49664	CLAMP, HOSE WORM, 2" FP, BNJ	7	
2	49663	GASKET, 2" FP, EPDM, BNJ	7	
3	49665	VALVE, 2" FP, 3 WAY, BOTTOM LOAD, BNJ	2	
4	49643	SEPARATOR PLATE, VALVE SELECTOR	1	
5	49738	CHAIN, ANSI HD35-1, 56P	1	
6	49642	SPROCKET W/A, DRIVE, VALVE SELEC.	1	
7	49640	SPROCKET W/A, DRIVEN, VAVLE SELEC.	1	
8	0304	SCREW, PHP 10-24 X 1/4" PLTD	4	
9	49647	GUARD, VALVE SELECTOR	1	
10	0169	SCREW, HHC 3/8-16 X 3"	1	
11	49662	FITTING, TEE, 2" FP, BNJ	2	
12	49660	FITTING, 2" FP X 3/4" FNPT, BNJ	1	
13	49683	HOSE BIB, 3/4" MNPT	1	
14	49907	HANDLE, VALVE 2" FP	1	
15	282901-001	WASHER, FENDER 3/8 X 1-1/4"	1	
16	23619	SCREW, HHFS 1/4-20 X 1-1/4', ZP	1	
17	49898	BRACKET, GUARD RETAINER	1	
18	49900	FITTING, 2"FPX 2" BARB, TRIMMED	1	

# REAR SPRAY VALVE ASSY.

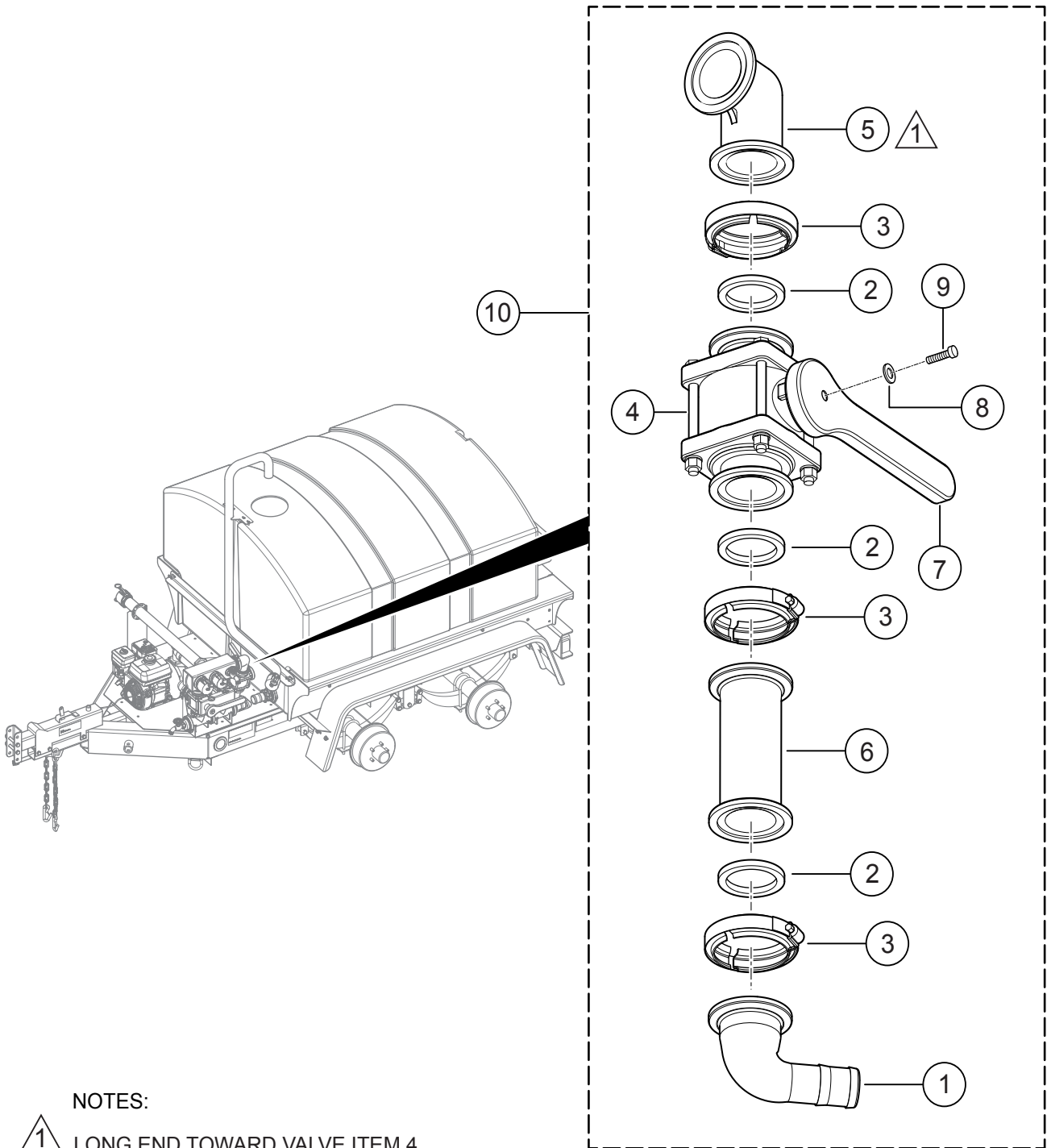

NOTES:

 LONG END TOWARD VALVE ITEM 4



## REAR SPRAY VALVE ASSY.

---

<u>NO.</u>	<u>PART NO.</u>	<u>PART NAME</u>	<u>QTY.</u>	<u>REMARKS</u>
1#	49661	FITTING, 90°, 2" FP X 1-1/2" BARB, BNJ	1	
2#	49663	GASKET, 2" FP, EPDM, BNJ	3	
3#	#49664	CLAMP, HOSE WORM, 2" FP, BNJ	3	
4#	49666	VALVE, 2" FP, BNJ	1	
5#	49669	FITTING, 90°, 2" FP, BNJ	1	
6#	49670	FITTING, NIPPLE, 2" FP X 6"L, BNJ	1	
7#	49907	HANDLE, VALVE, 2" FP	1	
8#	28290-001	WASHER, FENDER, 3/8 X 1-1/4"	1	
9#	0169	SCREW, HHC 3/8-16 X 3"	1	
10	49733	VALVE ASSY., REAR SPRAY .....	1.....	INCLUDES ITEMS W/#

# TANK CRADLE MOUNTING ASSY.

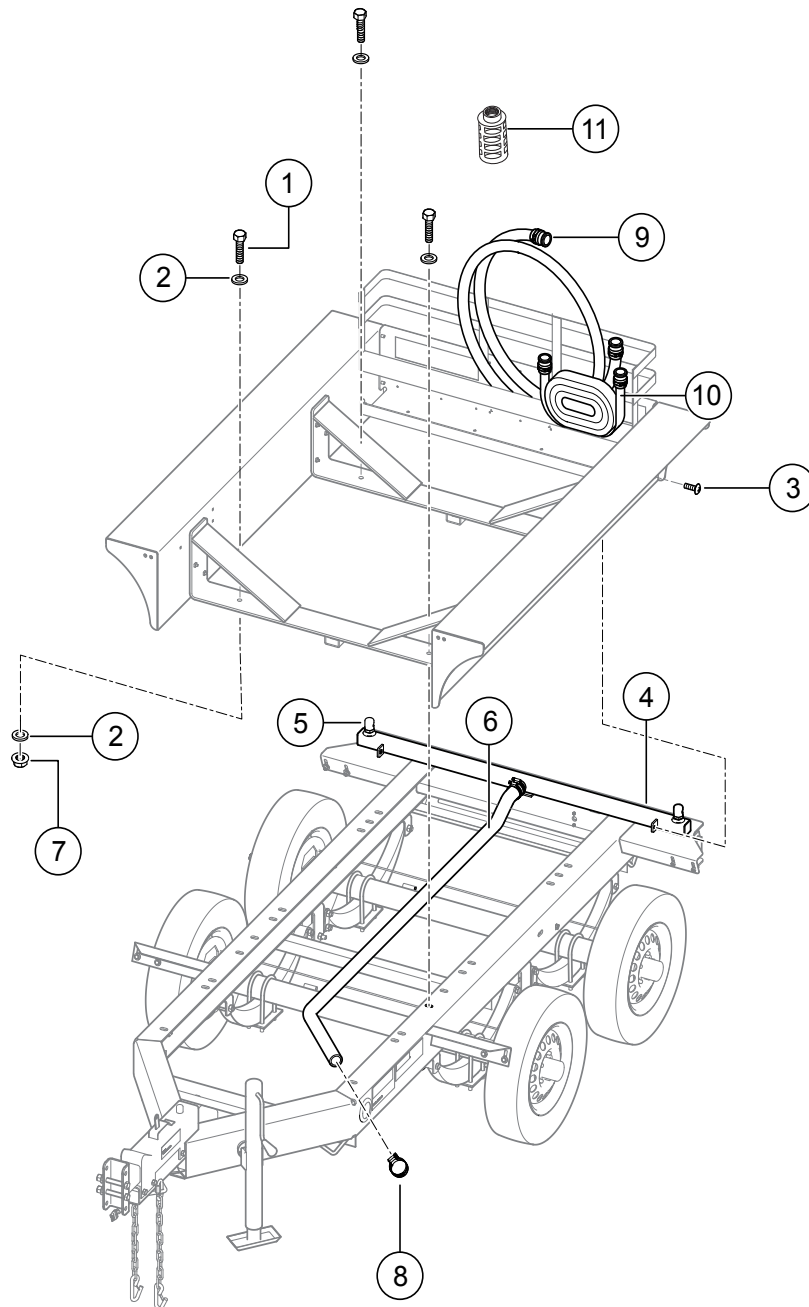

## TANK CRADLE MOUNTING ASSY.

---

<u>NO.</u>	<u>PART NO.</u>	<u>PART NAME</u>	<u>QTY.</u>	<u>REMARKS</u>
1	915311	SCREW, HHC 5/8-11X2" GR8 YZ	4	
2	933246	WASHER, FLAT 5/8" SAE GRD9 YZ	8	
3	12287	SCREW, THP 1/4-20 X 3/4" SS	2	
4	49780	SPRAY BAR, REAR, W/A	1	
5	49781	NOZZLE, SPRAY, 3/4"	2	
6	49850	HOSE, RUBBER, 1-1/2", 125 PSI	1	
7	937188	NUT, NYLOC 5/8-11, GR8	4	
8	12277	CLAMP, HOSE WORM # 36	4	
9	HSQ220	HOSE, SUCTION, 2" X 20' QUICK COUP.	1	
10	HDQ250	HOSE, DISCHARGE, 2" X 50' QUICK COUP.	1	
11	0742303050	PLASTIC STRAINER	1	

# TANK CRADLE ASSY.

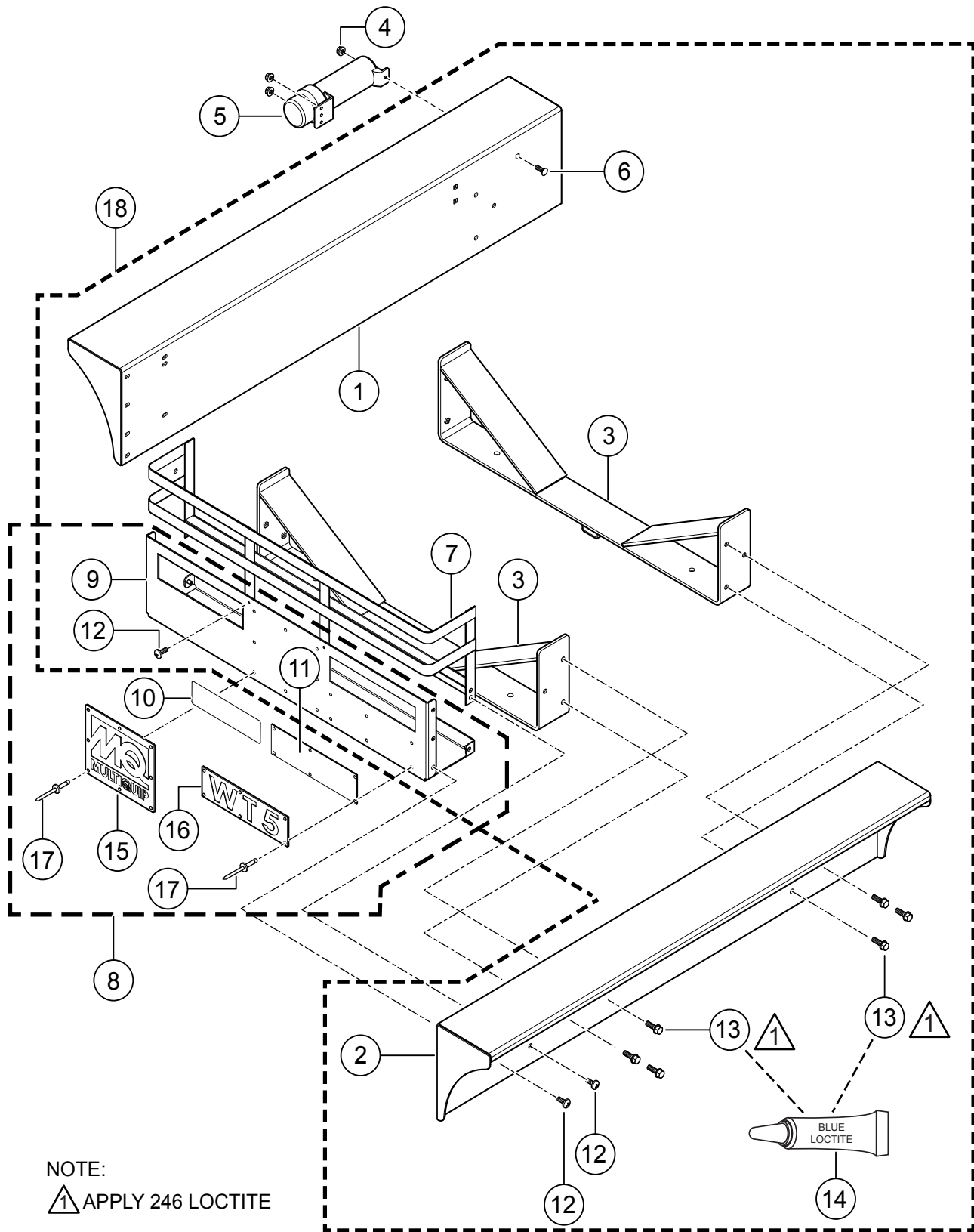

## TANK CRADLE ASSY.

<u>NO.</u>	<u>PART NO.</u>	<u>PART NAME</u>	<u>QTY.</u>	<u>REMARKS</u>
1%	49635	CRADLE, SHELF, W/A. LH	1	
2%	49634	CRADLE, SHELF, W/A. RH	1	
3%	49629	CRADLE BASE, W/A.	2	
4	49070	NUT, FLANGED 1/4-20 SERRATED PLTD	3	
5	23297	MANUAL HOLDER	1	
6	29712	BOLT, CARRIAGE 1/4-20 X 3/4"	3	
7%	49622	BASKET, REAR, UPPER, W/A.	1	
8	49626	BASKET, REAR, ASSY.....	1	INCLUDES ITEMS W/#
9%#	49625	BASKET, REAR , TRAY	1	
10#	49618	DECAL, CRADLE BADGE	1	
11#	49624	BADGE, CRADLE, WT5, BACKING	1	
12%	49048	SCREW, HHFS 1/4-20 X 3/4" GRD 5	14	
13%	9091	SCREW, HHFS 5/16-18 X 1" GRD5	12	
14	60097	LOCTITE, #246 BLUE	AR	
15#	49617	BADGE, CRADLE, REAR	1	
16#	49623	BADGE, CRADLE WT5	1	
17#	19847	RIVER, POP, ALUM., 3/16" X 1/8"-1/4" GRIP	14	
18	49637	TANK CRADLE ASSY.....	1	INCLUDES ITEMS W/%

# HYDRAULIC TRAILER ASSY.

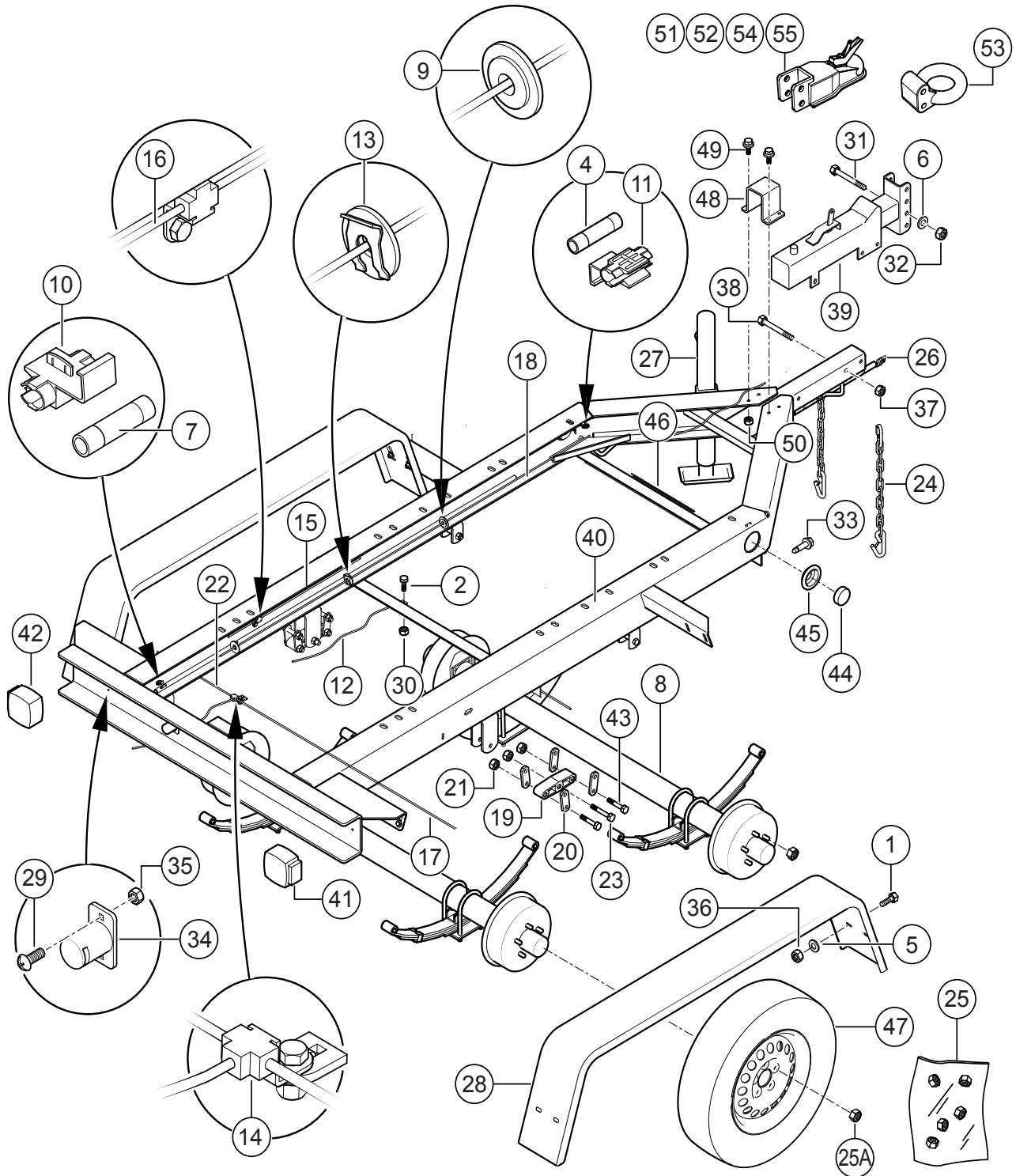

## HYDRAULIC TRAILER ASSY.

<u>NO.</u>	<u>PART NO.</u>	<u>PART NAME</u>	<u>QTY.</u>	<u>REMARKS</u>
1	0205	SCREW, HHC3/8-16 X 1"	8	
2	0655	SCREW, HHC 5/16-18 X 3/4"	3	
4	2540	CONNECTOR, BUTT SPLICE, 16-14	3	
5	4001	WASHER, FLAT USS 3/8 PLTD	16	
6	4684	WASHER, FLAT SAE 5/8 PLTD	2	
7	9512	INSULATOR, WIRING .50 DIA	8	
8	19070	AXLE, TRLR70 COMPLETE W/A	2	
9	19468	GROMMET,3/16 x 1/2ID Xx 1-1/4OD	1	
10	19761	TERMINAL, SPLICE 16-14 CLSD', BLUE	1	
11	19762	TERMINAL, SPLICE 16-14 CLSD', BRN/WHT	1	
12	19763	HOSE, DOT BRAKE, 3/16 X 19", MALE/FEM	3	
13	29226	TAB, SPRING LOCK TRLR70	3	
14	29227	TEE, BRAKE LINE 3/16 W/ STRAP	3	
15	29236	TUBE, BRAKE 5.5"	1	
16	29237	TUBE, BRAKE 3/16 X 20"	1	
17	29238	TUBE, BRAKE 3/16 x 41-1/2"	2	
18	29239	BRAKE LINE 74"	1	
19	29246	EQUALIZER, TANDEM AXLE	2	
20	29247	SHACKLE, AXLE MOUNTING	8	
21	29249	NUT, 9/16-18 AXLE MOUNTING N-2	14	
22	29251	TUBE, BRAKE 15"	2	
23	29317	SCREW, 9/16 X 3-1/2 AXLE MOUNTING	2	
24	29572	CHAIN ASM, SAFETY 7600 LB	2	
25	29755	KIT, LUG NUTS, 1/2-20 PLTD.....	1.....	INCLUDES ITEM W/%
25A%	29194	NUT, LUG 1/2 - 20 TAPPERED CONE, PLTD	20	
26	29784	HARNES ASM 48" LOOM W/4 PIN CONN.	1	
27	49116	JACK, SWIVEL 15" LIFT, 5/8" PIN	1	
28	49842	FENDER, TANDEM 8" x 15.5" x 66"	2	
29	5065 B	SCREW, PHP 10-32 X 1/2"	4	
30	5283	NUT, NYLOC 5/16-18	3	

# HYDRAULIC TRAILER ASSY. (CONTINUED)

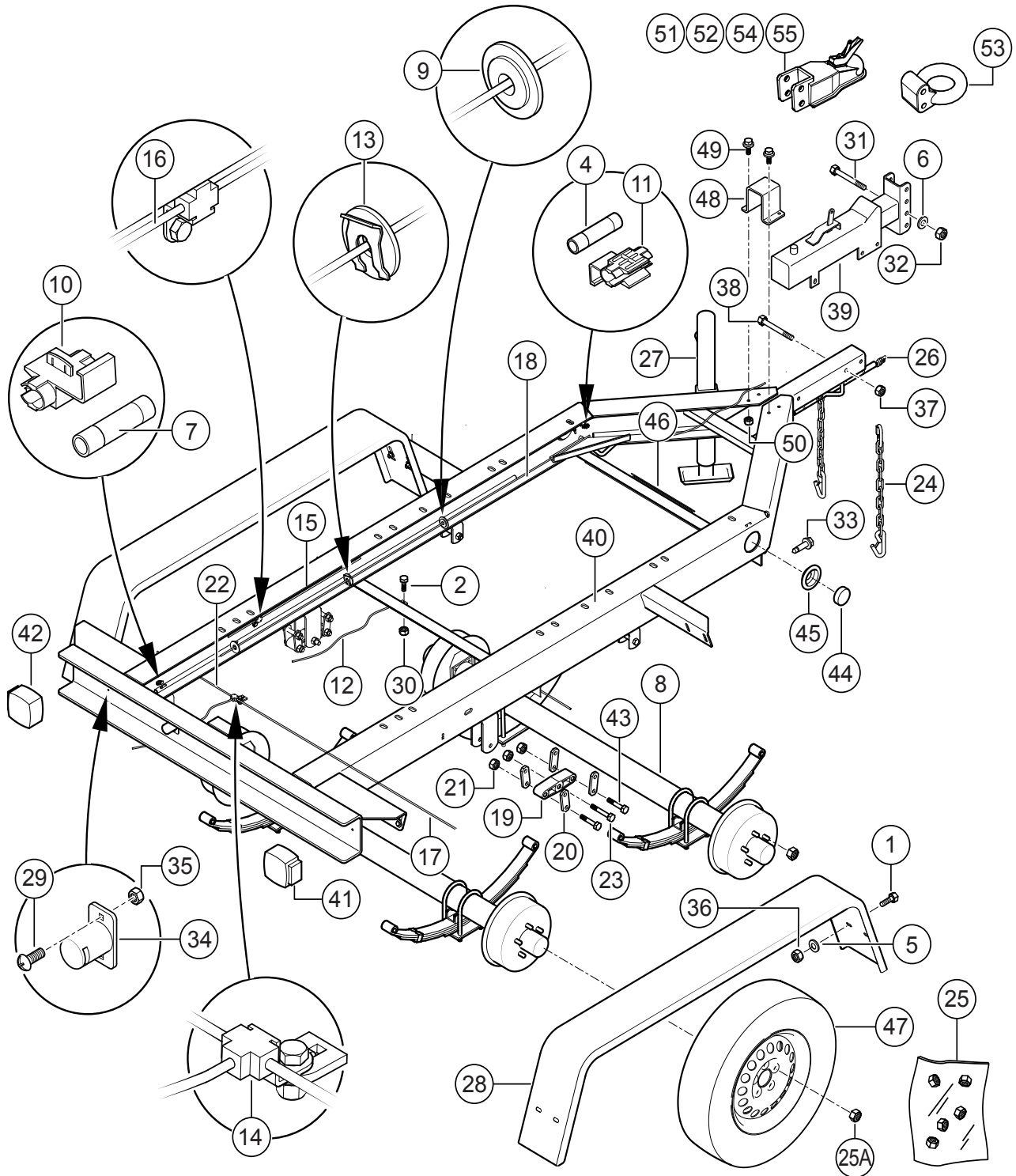



## HYDRAULIC TRAILER ASSY. (CONTINUED)

<u>NO.</u>	<u>PART NO.</u>	<u>PART NAME</u>	<u>QTY.</u>	<u>REMARKS</u>
31	37826	SCREW, HHC 5/8-11 X 4-3/4" GRD 8 YZ	2	
32	9503	NUT, NYLOC 5/8-11	2	
33	9509	SCREW, TEK 12 X 3/4 SELF TAP	3	
34	9514	LIGHT ASM, LICENSE PLATE	2	
35	10019	NUT, NYLOC 10-32	4	
36	10133	NUT, NYLOC 3/8-16	8	
37	10176	NUT, NYLOC 1/2-13	3	
38	10306	SCREW, HHC 1/2-13 X 4-1/2"	3	
39	19067	ACTUATOR, BRAKE DEMCO DA-91	1	
40	19748	FRAME W/A, TRLR70	1	
41	29242	LIGHT, TAIL RT (CURB) SIDE M440	1	
42	29243	LIGHT, TAIL LT (ROAD) SIDE M440L	1	
43	29248	SCREW, HHC 9/16-18 x 3"	12	
44	29898	LIGHT, 2-1/2 SIDE MARKER, AMBER	2	
45	29900	GROMMET W/WIRE KIT, 2-1/2"	2	
46	60018	WIRE, 16 GA. BROWN, SAE J1128 .....	4	1PC = 1FT
47	EE44304	WHEEL ASSY., ST205/75D-14 L/R,"C"	4	
48	49975	BRAKE HOSE COVER, BOLT- ON	1	
49	49048	SCREW, HHFS 1/4 - 20 X 3/4" GRD 5	4	
50	49070	NUT, FLANGED 1/4 - 20 SERRATED PLTD	4	
51	EE43253	HITCH, BALL, 2-5/16" (STANDARD) .....	1	CONTACT UNIT SALES DEPT.
52	29228	HITCH, BALL, 2" ADJUSTABLE (OPTION) .....	1	CONTACT UNIT SALES DEPT.
53	29369	HITCH, PINTLE, 3" ADJUSTABLE(OPTION) ....	1	CONTACT UNIT SALES DEPT.
54	EE56638	HITCH, BULLDOG, 2-5/16" BALL, ADJ. (OPT.)	1	CONTACT UNIT SALES DEPT.
55	EE57033	HITCH, BULLDOG, 2" BALL, ADJ. (OPT.) .....	1	CONTACT UNIT SALES DEPT.

# ELECTRIC TRAILER ASSY.

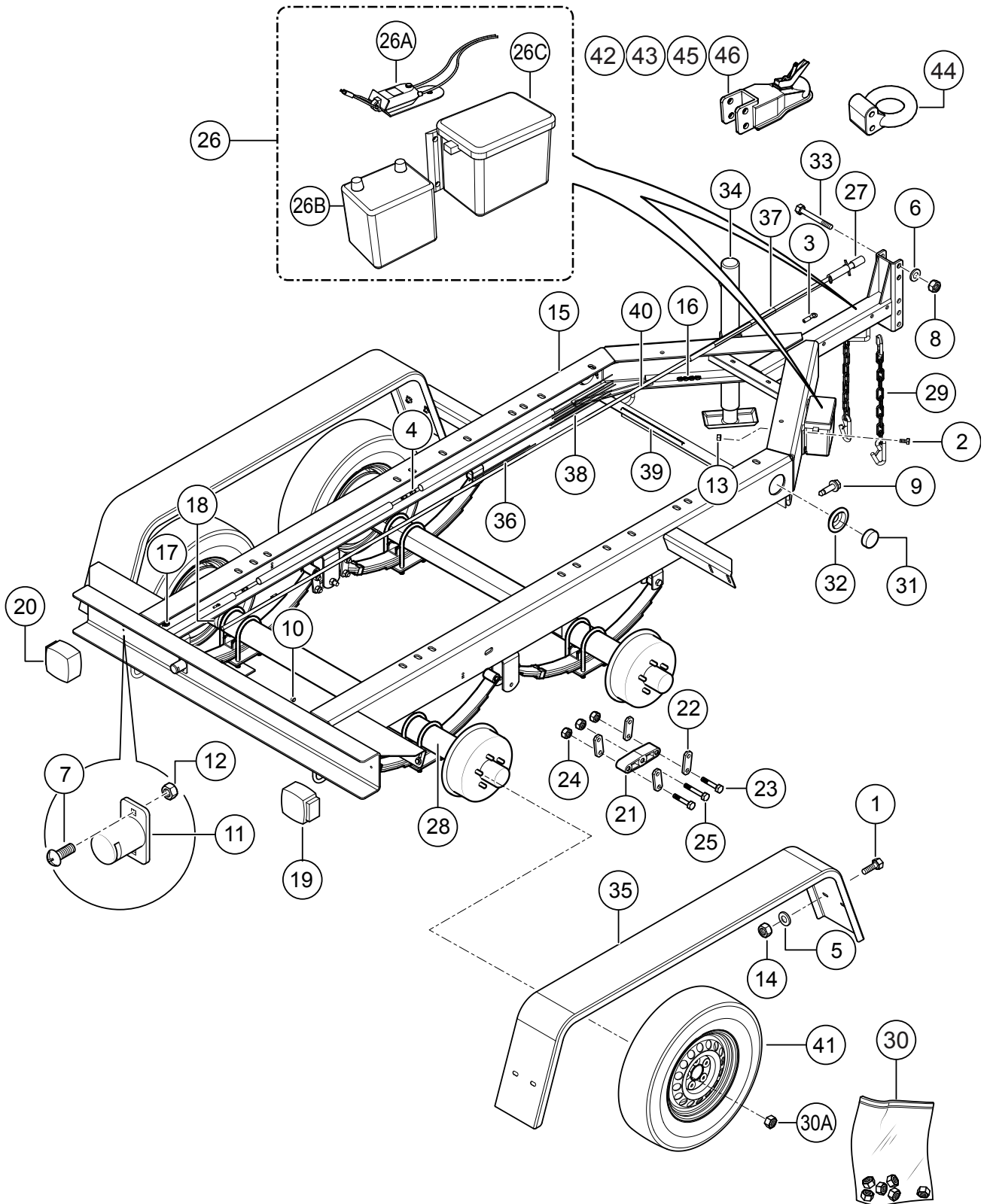

## ELECTRIC TRAILER ASSY.

<u>NO.</u>	<u>PART NO.</u>	<u>PART NAME</u>	<u>QTY.</u>	<u>REMARKS</u>
1	205	SCREW, HHC 3/8-16 X1.0	8	
2	730	SCREW, HHC 1/4-20 X 1	4	
3	1319	TERMINAL, RING 16-14 1/4" LOOP	2	
4	2540	CONNECTOR, BUTT SPLICE, 16-14	4	
5	4001	WASHER, FLAT USS 3/8 PLD	16	
6	4684	WASHER, FLAT SAE 5/8 PLTD	2	
7	5065 B	SCREW, PHP 10-32 X 1/2	4	
8	9503	NUT, NYLOC 5/8-11	2	
9	9509	SCREW, TEK 12 X 3/4 SELF TAP	4	
10	9512	INSULATOR, WIRING .50 DIA	4	
11	9514	LIGHT ASM, LICENSE PLATE	2	
12	10019	NUT, NYLOC 10-32	4	
13	10024	NUT, NYLOC 1/4-20	4	
14	10133	NUT, NYLOC 3/8-16	8	
15	19748E	FRAME W/A, TRLR70WE	1	
16	19761	TERM., SPLICE 16-14 CLOSED, BLUE	4	
17	19762	TERM., SPLICE 16-14 CLOSED, BRN/WHT	1	
18	29218	CLAMP, HOSE WORM, 2-1/2" TO 3-1/2"	2	
19	29242	LIGHT, TAIL RT (CURB) SIDE M440	1	
20	29243	LIGHT, TAIL LH (ROAD) SIDE	1	
21	29246	EQUALIZER, TANDEM AXLE	2	
22	29247	SHACKLE, AXLE MOUNTING	8	
23	29248	SCREW, HHC 9/16-18	12	
24	29249	NUT, 9/16-18 AXLE MOUNTING N-2	14	
25	29317	SCREW, 9/16 X 3-1/2 AXLE MOUNTING	2	
26	29366	KIT, BREAK-AWAY, TRAILER 70 .....	1	INCLUDES ITEMS W/#
26A#	EE43519	SWITCH, BREAK-AWAY, KIT	1	
26B#	EE57140	BATTERY, BREAK-AWAY, KIT	1	
26C#	EE57141	BOX, BATTERY, BREAK-AWAY, KIT	1	
27	29367	PLUG/SPRING, 6 POLE TRAILER	1	
28	29396	AXLE ASM, 3500 LB W/ELEC BRAKE	2	
29	29572	CHAIN ASM, SAFETY 7600 LB	2	
30	29755	KIT, LUG NUTS, 1/2-20 PLTD .....	1	INCLUDES ITEM W/%
30A%	29194	NUT, LUG 1/4-20 TAPPED CONE, PLTD	20	
31	29898	LIGHT, 2-1/2 SIDE MARKER, AMBER	2	
32	29900	GROMMET W/WIRE KIT, 2-1/2", 14218K	2	
33	37826	SCREW, HHC 5/8-11 X 4-3/4 GRD 8 YZ	2	
34	49116	JACK, SWIVEL 15" LIFT, 5/8" PIN	1	
35	49842	FENDER, TANDEM 8 x 15.5 x 65.25	2	
36	60018	WIRE, 16 GA. BROWN, SAE J1128	4	
37	60037	LOOM, 5/8 DIA HI-TEMP, BLK	3	
38	60043	WIRE, 16GA GREEN, SAE J1128	7	

# ELECTRIC TRAILER ASSY.(CONTINUED)

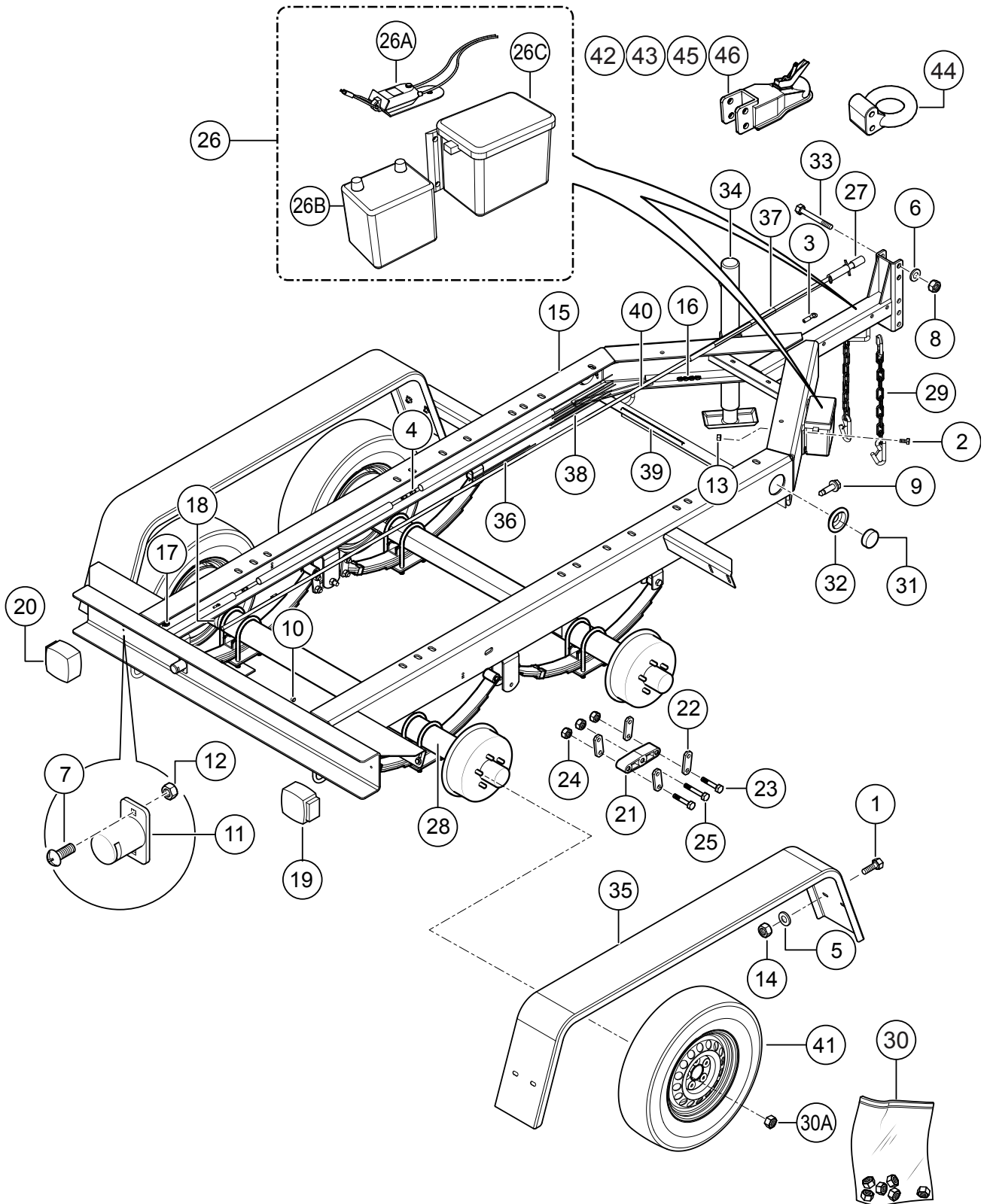

## **ELECTRIC TRAILER ASSY.(CONTINUED)**

---

<u>NO.</u>	<u>PART NO.</u>	<u>PART NAME</u>	<u>QTY.</u>	<u>REMARKS</u>
39	60221	LOOM, .375 SPLIT	5	
40	60257	WIRE, TRAILER, 6 COND. 14 GA. ....	19	1PC=1FT
41	EE44304	WHEEL ASSY, ST205/75D-14 L/R,"C"	4	
42	EE43253	HITCH, BALL 2-5/16" (STANDARD) .....	1	CONTACT UNIT SALES DEPT.
43	29228	HITCH, BALL 2" ADJUSTABLE (OPTION) .....	1	CONTACT UNIT SALES DEPT.
44	29369	HITCH, PINTLE 3" ADJUSTABLE, (OPTION) ...	1	CONTACT UNIT SALES DEPT.
45	EE56638	HITCH, BULLDOG, 2-5/16" BALL, ADJ. (OPT.)	1	CONTACT UNIT SALES DEPT.
46	EE57033	HITCH, BULLDOG, 2" BALL, ADJ. (OPT.) .....	1	CONTACT UNIT SALES DEPT.

# TERMS AND CONDITIONS OF SALE — PARTS

## PAYMENT TERMS

Terms of payment for parts are net 30 days.

## FREIGHT POLICY

All parts orders will be shipped collect or prepaid with the charges added to the invoice. All shipments are F.O.B. point of origin. Multiquip's responsibility ceases when a signed manifest has been obtained from the carrier, and any claim for shortage or damage must be settled between the consignee and the carrier.

## MINIMUM ORDER

The minimum charge for orders from Multiquip is \$15.00 net. Customers will be asked for instructions regarding handling of orders not meeting this requirement.

## RETURNED GOODS POLICY

Return shipments will be accepted and credit will be allowed, subject to the following provisions:

1. A Returned Material Authorization must be approved by Multiquip prior to shipment.
2. To obtain a Return Material Authorization, a list must be provided to Multiquip Parts Sales that defines item numbers, quantities, and descriptions of the items to be returned.
  - a. The parts numbers and descriptions must match the current parts price list.
  - b. The list must be typed or computer generated.
  - c. The list must state the reason(s) for the return.
  - d. The list must reference the sales order(s) or invoice(s) under which the items were originally purchased.
  - e. The list must include the name and phone number of the person requesting the RMA.
3. A copy of the Return Material Authorization must accompany the return shipment.
4. Freight is at the sender's expense. All parts must be returned freight prepaid to Multiquip's designated receiving point.

5. Parts must be in new and resalable condition, in the original Multiquip package (if any), and with Multiquip part numbers clearly marked.
6. The following items are not returnable:
  - a. Obsolete parts. (If an item is in the price book and shows as being replaced by another item, it is obsolete.)
  - b. Any parts with a limited shelf life (such as gaskets, seals, "O" rings, and other rubber parts) that were purchased more than six months prior to the return date.
  - c. Any line item with an extended dealer net price of less than \$5.00.
  - d. Special order items.
  - e. Electrical components.
  - f. Paint, chemicals, and lubricants.
  - g. Decals and paper products.
  - h. Items purchased in kits.
7. The sender will be notified of any material received that is not acceptable.
8. Such material will be held for five working days from notification, pending instructions. If a reply is not received within five days, the material will be returned to the sender at his expense.
9. Credit on returned parts will be issued at dealer net price at time of the original purchase, less a 15% restocking charge.
10. In cases where an item is accepted, for which the original purchase document can not be determined, the price will be based on the list price that was effective twelve months prior to the RMA date.
11. Credit issued will be applied to future purchases only.

## PRICING AND REBATES

Prices are subject to change without prior notice. Price changes are effective on a specific date and all orders received on or after that date will be billed at the revised price. Rebates for price declines and added charges for price increases will not be made for stock on hand at the time of any price change.

Multiquip reserves the right to quote and sell direct to Government agencies, and to Original Equipment Manufacturer accounts who use our products as integral parts of their own products.

## SPECIAL EXPEDITING SERVICE

A \$35.00 surcharge will be added to the invoice for special handling including bus shipments, insured parcel post or in cases where Multiquip must personally deliver the parts to the carrier.

## LIMITATIONS OF SELLER'S LIABILITY

Multiquip shall not be liable hereunder for damages in excess of the purchase price of the item with respect to which damages are claimed, and in no event shall Multiquip be liable for loss of profit or good will or for any other special, consequential or incidental damages.

## LIMITATION OF WARRANTIES

No warranties, express or implied, are made in connection with the sale of parts or trade accessories nor as to any engine not manufactured by Multiquip. Such warranties made in connection with the sale of new, complete units are made exclusively by a statement of warranty packaged with such units, and Multiquip neither assumes nor authorizes any person to assume for it any other obligation or liability whatever in connection with the sale of its products. Apart from such written statement of warranty, there are no warranties, express, implied or statutory, which extend beyond the description of the products on the face hereof.

Effective: February 22, 2006



# OPERATION AND PARTS MANUAL

## HERE'S HOW TO GET HELP

PLEASE HAVE THE MODEL AND SERIAL  
NUMBER ON-HAND WHEN CALLING

### UNITED STATES

#### ***Multiquip Corporate Office***

18910 Wilmington Ave.  
Carson, CA 90746  
Contact: mq@multiquip.com

Tel. (800) 421-1244  
Fax (310) 537-3927

#### ***Service Department***

800-421-1244  
310-537-3700

Fax: 310-537-4259

#### ***Technical Assistance***

800-478-1244

Fax: 310-943-2238

#### ***MQ Parts Department***

800-427-1244  
310-537-3700

Fax: 800-672-7877  
Fax: 310-637-3284

#### ***Warranty Department***

800-421-1244  
310-537-3700

Fax: 310-943-2249

### MEXICO

#### ***MQ Cipsa***

Carr. Fed. Mexico-Puebla KM 126.5  
Momoxpan, Cholula, Puebla 72760 Mexico  
Contact: pmastretta@cipsa.com.mx

Tel: (52) 222-225-9900  
Fax: (52) 222-285-0420

### CANADA

#### ***Multiquip***

4110 Industriel Boul.  
Laval, Quebec, Canada H7L 6V3  
Contact: jmartin@multiquip.com

Tel: (450) 625-2244  
Tel: (877) 963-4411  
Fax: (450) 625-8664

### UNITED KINGDOM

#### ***Multiquip (UK) Limited Head Office***

Unit 2, Northpoint Industrial Estate,  
Globe Lane,  
Dukinfield, Cheshire SK16 4UJ  
Contact: sales@multiquip.co.uk

Tel: 0161 339 2223  
Fax: 0161 339 3226

© COPYRIGHT 2013, MULTIQUIP INC.

Multiquip Inc, the MQ logo and the Whiteman logo are registered trademarks of Multiquip Inc. and may not be used, reproduced, or altered without written permission. All other trademarks are the property of their respective owners and used with permission.

This manual MUST accompany the equipment at all times. This manual is considered a permanent part of the equipment and should remain with the unit if resold.

The information and specifications included in this publication were in effect at the time of approval for printing. Illustrations, descriptions, references and technical data contained in this manual are for guidance only and may not be considered as binding. Multiquip Inc. reserves the right to discontinue or change specifications, design or the information published in this publication at any time without notice and without incurring any obligations.

Your Local Dealer is:



**PN: 49859**